

ON LOAD GEARS



OPERATIONAL AND MAINTENANCE MANUAL

VACUUM CIRCUIT BREAKER TYPE VS36

We thank you for having purchased VCB's from us. We are sure you will be very happy with the performance and service of the VCB you have bought. The breaker is designed very robustly and very long and satisfactory service may be expected of it.

In the following pages, we describe some simple operational procedures and routine maintenance requirements. We hope this manual would be of use to you for your day to day operations.

SPECIAL INSTRUCTIONS

1. RED Painted Mark, wherever made in the mechanism, denotes factory setting. This should not be altered without the presence of special maintenance wiring or manufacturer's service personnel
2. Before commissioning, the anti-condensation heaters should be switched on for warming the insulation parts
3. To ensure soundness of insulation, Drive power Frequency tests to be done before commissioning (for 36 KV system, 70KV for 1 Min).If IR value only checked due to HV kit non –Availability, minimum of 200 mega ohms must be ensured. (This is as per IS 10118, Part III. Clause 2.3.10.2)
4. Ensure that all covers and doors are securely tightened after carrying out Site work.

OPERATION AND MAINTENANCE MANUAL FOR VACUUM CIRCUIT BREAKER TYPE VS 36

CONTENTS

1. Description
2. Transport
3. The VCB
4. The Pole
5. The Mechanism
6. Electrical
7. Factory Settings
8. Lubrication
9. Fundamentals for Assembly of VS36

1. Description (Fig. 1)

The 36 KV PCVCB type VS36 is rated 36 KV,1250/1600/2000A with rupturing capacity of up to 1500MVA. It is normally supplied in 2 parts. The upper part consists of poles and operating mechanism, the lower part is a fabricated structure (an optional item) to give the required ground clearance for the live parts. CT & PT structure (also an optional item) can be supplied as an optional and will constitute with the third part

2. Transport & Handling

The VCB is transported with the wooden sleepers bolted to the bottom (fig. 2). CRANE & SLINGS AS SHOWN IN THE DRAWING MUST BE USED TO LIFT THE VCB. ANY OTHER METHOD IS LIKELY TO CAUSE THE BREAKAGE OF PORCELAIN AND INTERRUPTERS

3. VCB

The construction of the VCB is rugged and is shaped like a 'T' (fig 2). The horizontal part is a box of sheet steel folded, welded and reinforced adequately and supports the 3 poles of VCB. Inside the Box three support blocks are housed supporting the Drive Flat which operates the pole. The fourth support is provided closed to the middle pole. The vertical member is also a rectangular box of folded sheet metal and is bolted to the top box. This lower box houses the operating mechanism and electricals. Bolted type undrilled gland plate is provided in this box to permit sealed entry of the cables. The top box has bolted covers in front and sides. The mechanical box has a hinged door. Cutouts are provided to see the indicators for ON-OFF, etc

4. POLE

There are three poles (RYB). The Pole (fig 3) consists of two hollow porcelain insulators, two aluminum pads, Vacuum Interrupter, Compression springs, insulator operating rod and turn buckle. The joints for flanges and aluminum pad are sealed with rubber rings. The joint of the bottom flange of the bottom insulators and top of the sheet metal box are seated with rubber rings.

5. Mechanism

The mechanism (fig 4) is rugged and is so constructed that every part is visible and accessible. The operating mechanism is assembled iron steel plate. The mechanism consists of a gear box, charging device, main Spring, main Shaft with operating cranks, Latches for spring charged conditions and closed conditions, a motor as optional requirement, "Keep Open" Spring, Dash pot Damper, Indications and a Counter

1) GEAR BOX

The manual spring charging operation is carried out by cranking the gear box, which drives the charging pawl through a connecting rod. A motor can be mounted as an optional ground plate to drive this gear box to enable charging spring

II) CHARGING DEVICE

The worm wheel driven by the worm shaft rotates the coupler which is pinned to the Cam Shaft. The main Spring is attached to the eccentric on the cam shaft and gets compressed as the worm wheel is advanced by the charging action. The spring is fully charged when the eccentric reaches the top dead centre. Just as the eccentric cam move over the dead centre, a latch holds preventing the spring from discharging. In this position the charging part is also lifted off and will not move worm wheel further even if the handle continues to be rotated.

III) MAIN SHAFT

When the spring charge is released by opening the latch, either manually by push button or electrically by a close coil . The main spring rotates the Cam which in turn rotates the main shaft by moving the follower on the main crank. The operating crank moves simultaneously closing the vacuum interrupters. He contact compression springs are further compressed during this process , and a latch holds the closed position.

IV) LATCH

There are two latches in the mechanism. One holds the spring charge and the other keeps the breaker in the closed position. The latching is done using half Shaft and latch lever. The half shaft allows the lever to come out, but blocks it return path. The load thus stays latched. By turning half shaft slightly, the latch lever is released, either closing or opening the VCB.

V) KEEP OPEN SPRING

Also known as the opening spring, actually keeps the vacuum bottles open against the atmospheric pressure when breaker is open. When the breaker is closed the spring further expands and stores up some energy. When the breaker is opened, this energy from the contact compression springs open the breaker at the required speed.

VI) DAMPER

This is to dampen the impact, so that the mechanical stop does not rebound when the breaker open. The damping is done when oil is compressed due to the movement of the piston and this oil is forced to escape through a very small orifice

VII) INDICATIONS AND COUNTER

The indications show the status of the Breaker (ON- OFF), the counter shows the number of operations done by counting the number of spring charging.

6. ELECTRICALS

I) AUXILLARY SWITCH

Normally an 8 NO +8 NC auxiliary Switch is supplied. The Auxiliary switch is operated directly by the main shaft and this ensures that the correct sets of contacts are selected and the breaker will be operated automatically in response to the action of current/voltage operated relays.

II) LIMIT SWITCHES, RELAYS, OPENING & CLOSING

There is one limit switch which controls the motor. An Anti-Pumping relay prevents the repeated closing of the breaker in case of malfunction of close button. Two Coils are provided for closing and opening of the VCB (One Each).

7. SETTINGS

I. FACTORY SETTINGS

- a) Spring Charge Stroke Adjuster : See Fig.5
- b) Setting of Bell Crank : See Fig. 6
- c) Setting 'close' cap & Coil : See Fig. 7
- d) Setting 'Trip' Cap & Coil : See Fig. 8
- e) Gap in Bottle : See Fig. 9
- f) Snatch Gap : See Fig. 10

II. The VCB is set for the following parameters in the factory

- a) Gap between Cam & Roller : 11.0mm
- b) Gap in the interrupter : 20mm
- c) Snatch Gap : 3 mm
- d) Latch Overlap : 1.5mm
- e) Coils : 8mm

8. LUBRICATION (Fig. 4)

The performance of any moving part depends on lubrication. Proper lubrication ensures smooth operation. If lubrication is neglected, sluggish movement or "no movement" will result. This will lead to malfunctioning of the equipment, It is essential to lubricate the parts according to the chart to ensure perfect operation of the VCB.

	PART	LUBRICATION MEDIUM	PEROPD/NO.OF OPERATION
Fig. 4a Mechanism	Main Shaft Bearings	Grease	3 Months
	Operating Crank	Oil	15 days
	Roller Follower	Oil	15 days
	Cam Shaft Bearings	Grease	3 Months
	Latch base Plate Bearings	Oil	15 days
	Latch ,Latch Lever Bearings	Oil	15 days
	Trunnion	Oil	15 days
	Motor Gear Box Bearing	Grease	3 Months
	Fig. 4b Transmission	Hinge pin	Oil
Drive pin		Oil Pin	15 days

9. FUNDAMENTALS FOR ASSEMBLY OF OLG OUTDOOR VCB

I. SETTING GAP BETWEEN MAIN BELL CRANK ROLLER AND ECCENTRIC CAM

Set gap between Main Bell Crank Roller and Cam Shaft as 11.0+0.5 mm (fig.10)

II. SETTING OF BELL CRANK POLE ASSEMBLY COUPLING-SEE FIG.10

- 1) Disconnect bottle from bell crank.
- 2) Due to atmospheric pressure vacuum Bottle Contact will close.
- 3) Under this condition, Set dia 8.0 mm hole of the Bell Crank at 8 mm above the centre of Pivot axis and connect the pole to bell crank.
- 4) Open the bottle by using Screw Jack up to 20mm.
- 5) Then adjust the stopper bolt until it touches the drive flat.
- 6) Fix the keep opening spring with drive flat by using Screw Jack.

III. SETTING OF SNATCH GAP

Snatch gap allowed : 3-4 mm

If the above two steps are followed correctly, the snatch gap will be 3.0 mm when the breaker is in closed condition. If the snatch gap is more or less, only bottle gap can be adjusted. If any other adjustment are attempted other functions (Important Functions such as Auxiliary Switch Travel) will be got affected.

IV. AUXILLARY SWITCH SETTINGS-SEE FIG.11

- a) Set the Switch Crank centre line 12mm above the switch centre with VCB in off condition
- b) Connect both switch Crank and Operating Crank on the main Shaft with the link rod .Insert the split pin and fold
- c) Set and tighten the lock nuts so that there is only a minimum play of about 0.5mm
- d) Operate the breaker and measure the travel at switch crank which should not be less than 24mm

VI. SETTING OF TRIP CAP, COIL (TRIP TO OPEN)- SEE FIG. 8a & b

- a) When the breaker is closed, the trip coil should be positioned 8mm below the horizontal flap of trip cap and tightened. The trip button end should have no gap with vertical flap of the trip cap and tightened.

- b) The back stop for the horizontal flap of the trip cap should be adjusted such that there should be minimum play of 0.5 mm for the flap when the plunger is fully taken up by hand. This play is required to avoid bulging of trip coil stem

- c) If the latch does not hold on closing, the manual Trip Push button must be adjusted. To adjust the trip push button loosen the Grub Screw, hold the stem and rotate the trip Push button clock wise by half to one turn. Lock the grub screw, try closing the Breaker. If the breaker does not latch, repeat above. The latch should sit on the half shaft about 1.5mm. (Refer Fig.8C)

ERECTION AND COMMISSIONING OF SWITCHGEARS

The availability of following documents should be ensured during erection and commissioning:

1. Packing list
2. Instruction manual for operation and maintenance
3. Outline GA, Layout and floor plan drawing and foundation drawing.
4. Schematic and wiring diagrams
5. Instruction manual for relays, meters and other devices like switches, etc.

Inspection on receipt at site:

Switchgear is often dismantled before being dispatched with the parts packed desperately. All items of equipment should therefore be carefully inspected as soon as possible upon arrival at site to ascertain whether any items are missing or damaged. If any damages are noticed, communication of the same may sent to the transportation company, Insurance company and a copy to the manufacturer.

Pre-Commissioning Check list

A. Visual inspection	Observation
1. Breaker S.no	:
(a) S.No. of pole unit	:
(b) S.No of Mechanism	:
2. Check tightness of hardware	
(a) Between foundation frame and support structure	:
(b) Between support structure and coffin box	:
(c) Terminal connector tightness	:
3. Check leveling	:
4. Check porcelain	:
5. Check gasket of	
(a) door & covers	:
B. Mechanical Operation Check	
1. Mechanism should be Lubricated	:
2. Counter reading	:
3. Manual charging	: Smooth / Hard
4. Oil damper	: Ok / Jammed
5. Manual closing of breaker	: Ok / Not Ok
6. Stopper Bolt tightness	: Ok / Not Ok

C. Electrical Operation Check

1. Wiring check as per drg. :
2. Selector switch on local
 - (a) Electrical closing : Ok / Not Ok
 - (b) Electrical tripping : Ok / Not Ok
3. Selector switch on remote
 - (a) Electrical closing : Ok / Not Ok
 - (b) Electrical tripping on remote : Ok / Not Ok
4. Main contact resistance (max. 80micro-ohm) :
5. Insulation resistance after both terminals are disconnected:

Dos and Donts for site work

Do : Plan civil, Storage, Erection, Testing, Commissioning Activities
Do Not : Do unplanned site work

Do : Train site personnel
Do Not : Assign work to untrained personnel

Do : Prepare field quality documents
Do Not : Neglect documentation and records

Do : Take safety precautions
Do Not : Neglect Safety

Do : Receive and check packages on arrival and take to foundation if ready
Do Not : Neglect inspection for transit damage

Do : Inspect and store if site is not ready
Do Not : keep packages and breakers in field

Do : Erect the structure vertically
Do Not : Place breaker Assembly on structure

Do : Assemble the VCB with company setting
Do Not : Disturb any setting

Do : Carry out all pre-Commissioning tests
Do Not : Energise till completion of all tests

Do : Check for tightness of all hardwares
Do Not : Ignore loose Hardwares

Do : Complete Commissioning tests before energizing
Do Not : Forget safety and work permits

FIG-01

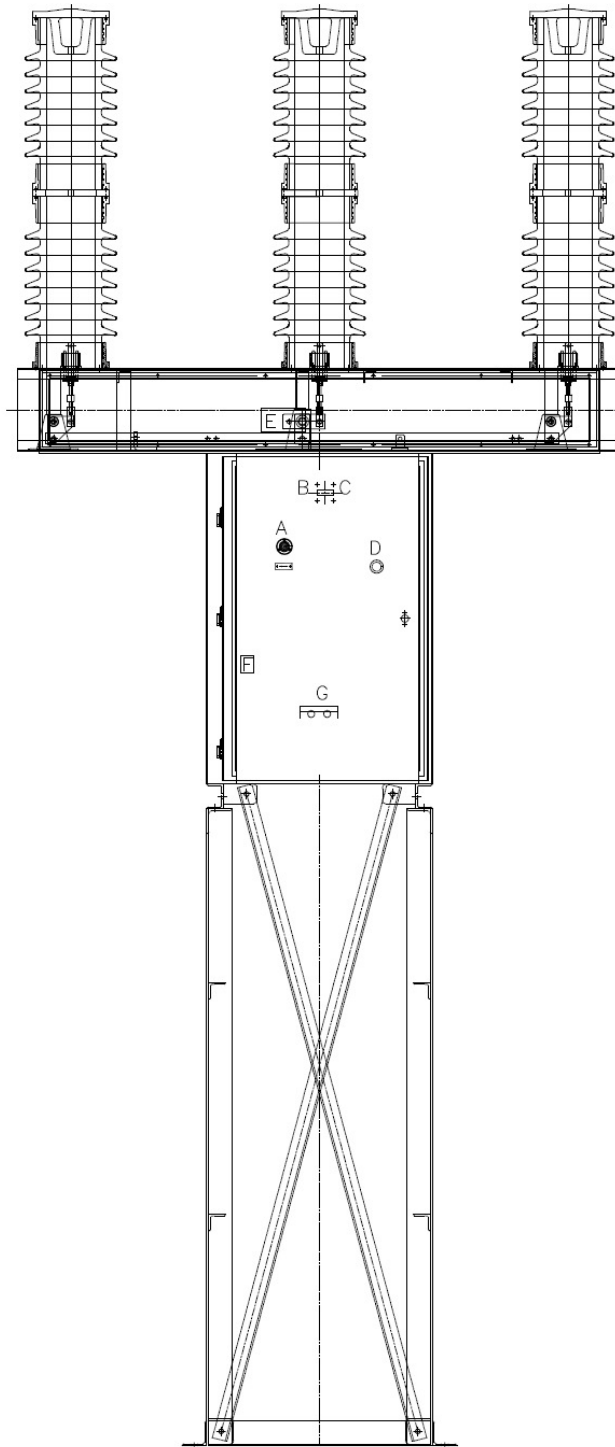

- A. MANUAL PUSH BUTTON FOR TRIP.(EMERGENCY TRIP)
- B. COUNTER
- C. SPRING CHARGE INDICATOR.
- D. MANUAL PUSH BUTTON FOR CLOSE (PROVIDED INSIDE)
- E. ON/OFF INDICATION
- F. LOCAL/REMOTE SWITCH
- G. ON/OFF PUSH BUTTON

On Load Gears

G.A. OF PCVCB

450 748

RO

FIG-02

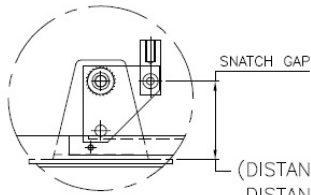

(-)
 (DISTANCE IN CLOSED POSITION MINUS
 DISTANCE IN OPEN POSITION MINUS 20mm BOTTLE GAP)
 SNATCH GAP = 3.0mm (-)
 OVER TRAVEL = 2.0mm
 BREAKER TRAVEL = 20 + 3 + 2 = 25mm

DETAIL-'X'

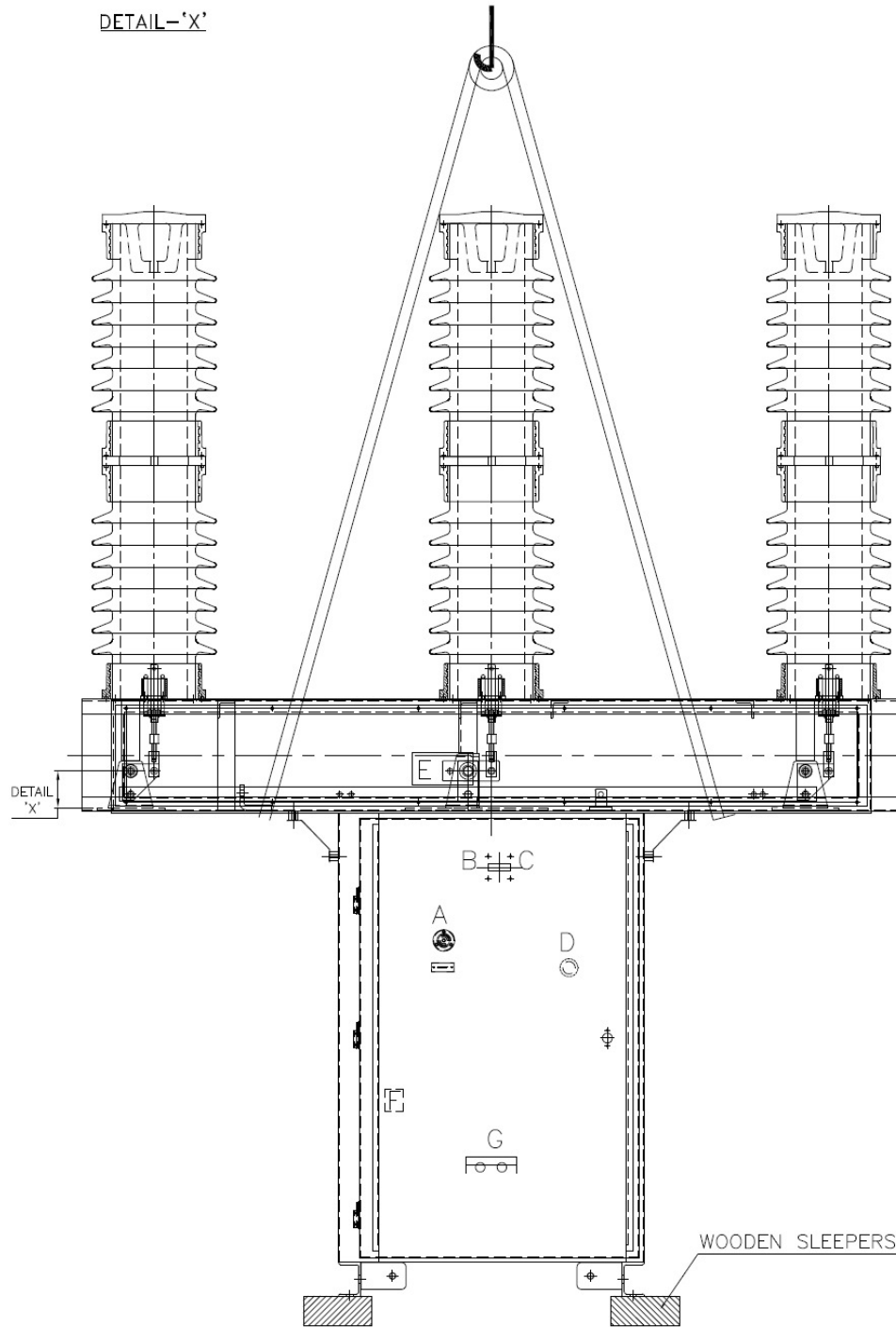

On Load Gears

VCB WITH POLE ASSY

450 749

RO

FIG-03

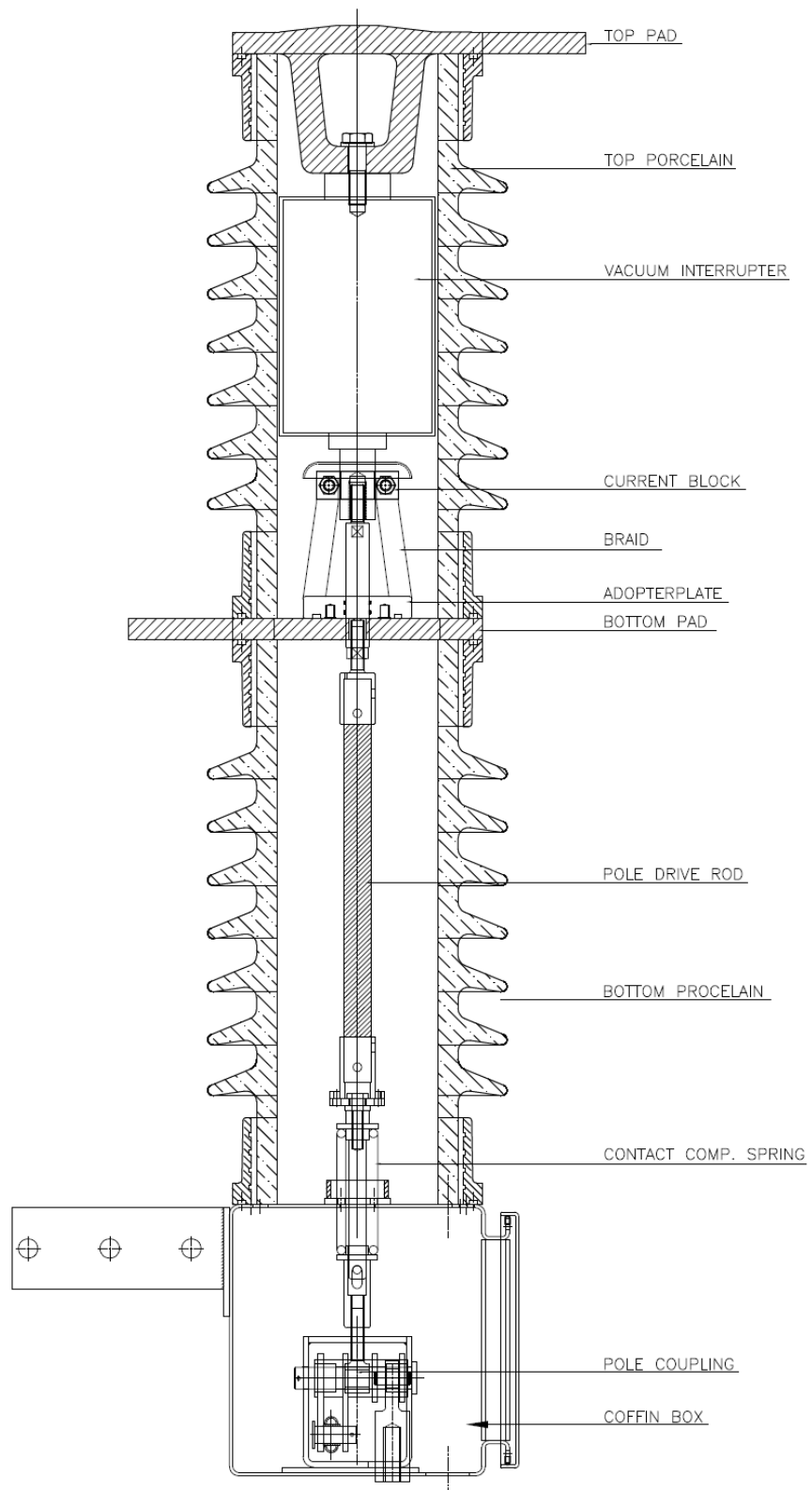

On Load Gears

POLE ASSY

450 750

RO

FIG-03

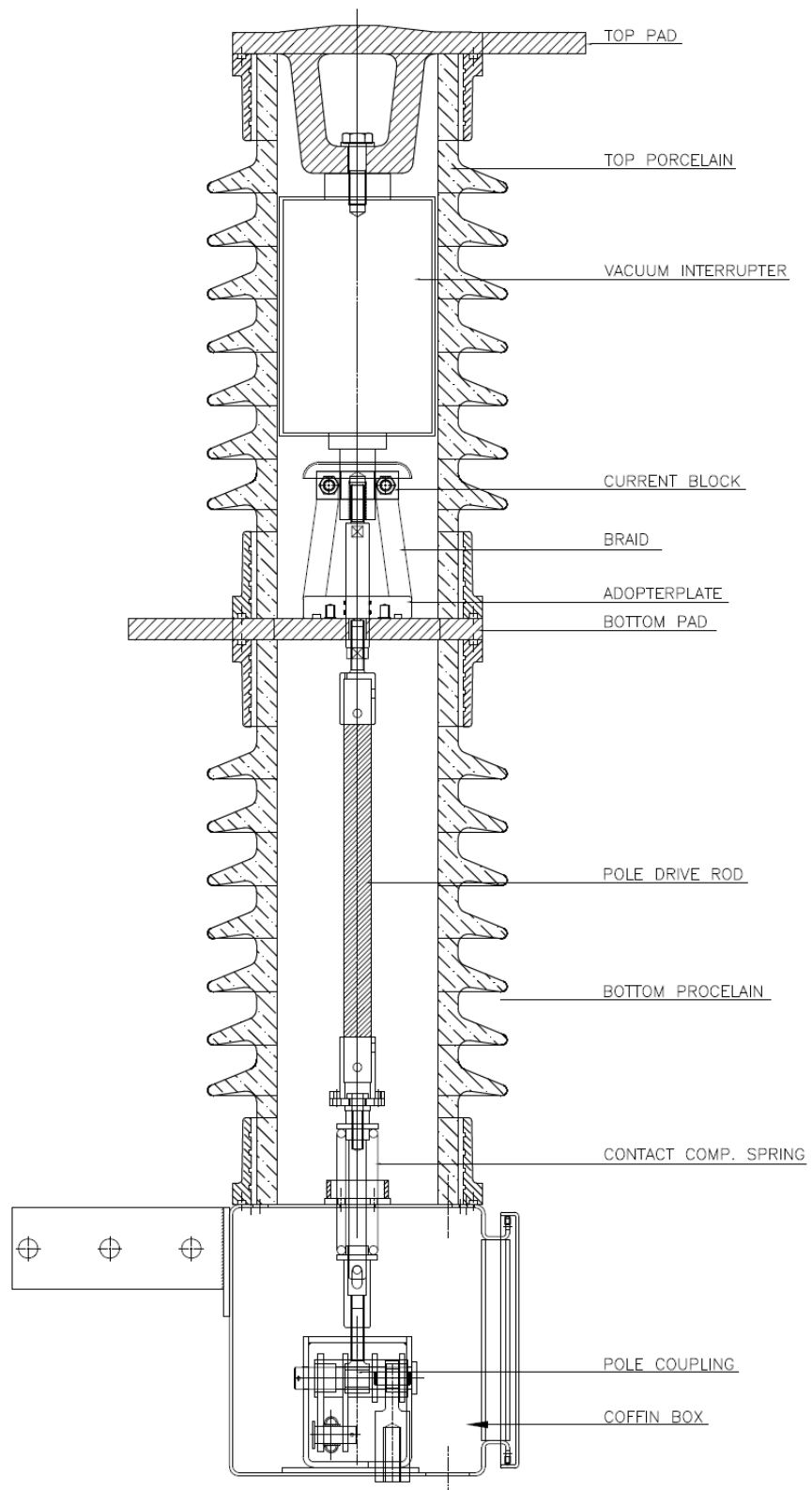

On Load Gears

POLE ASSY

450 750

RO

FIG-5

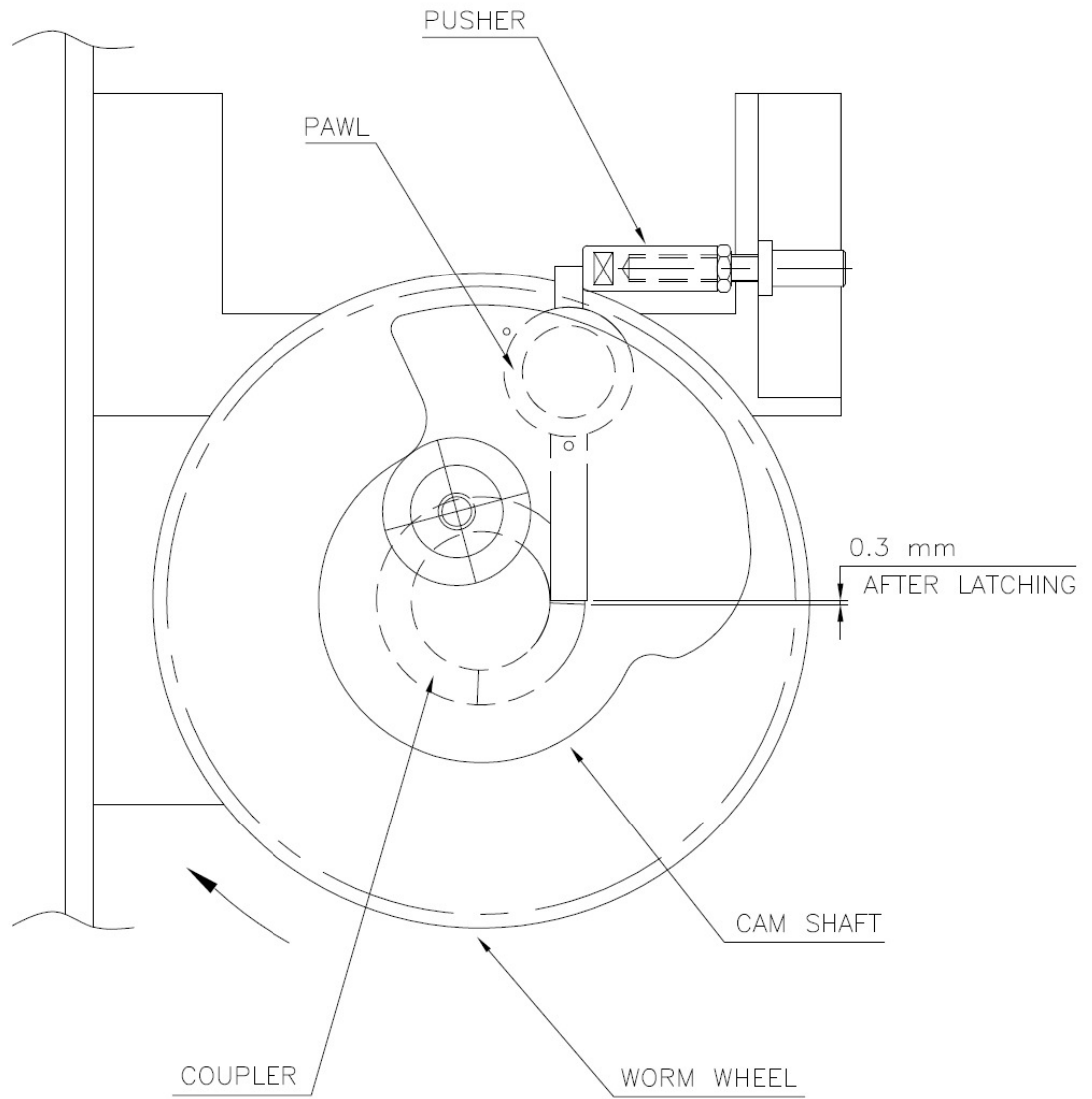

On Load Gears

SPRING CHARGE STROKE ADJUSTMENT

450 752

R 1

FIG-6

GAP SETTING BETWEEN MAINBELL
CRANK ROLLER AND RATCHET SHAFT.

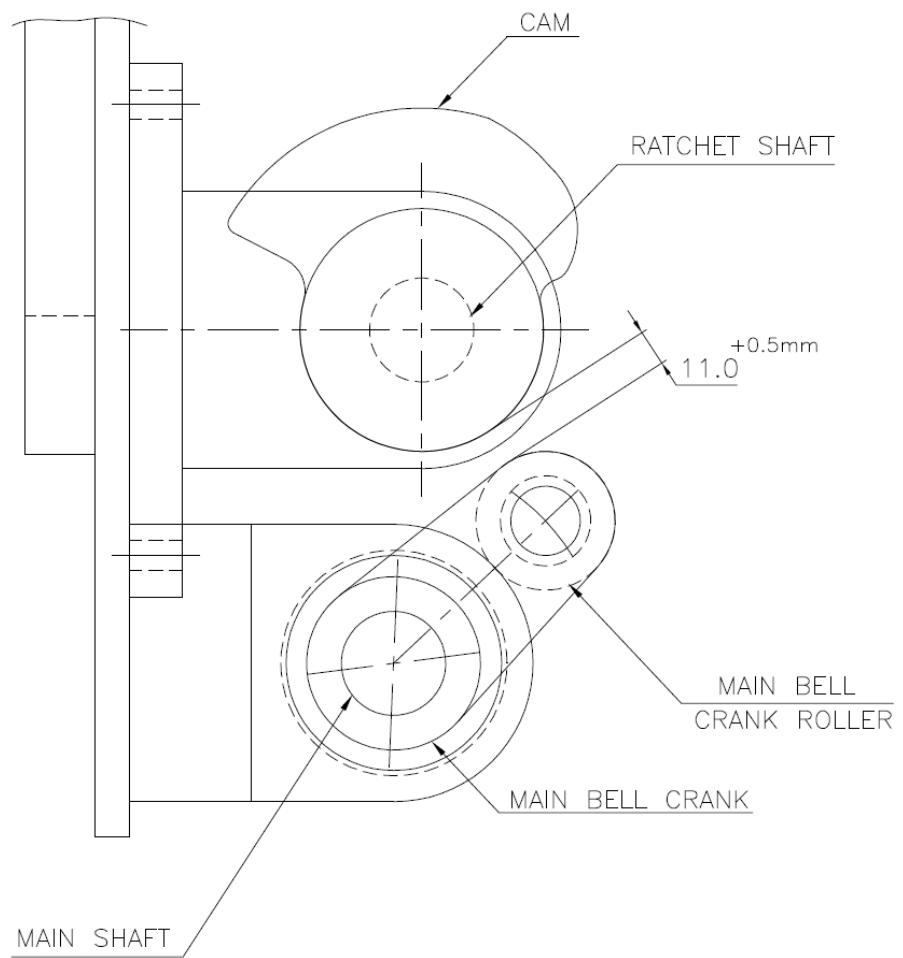

FIG-7

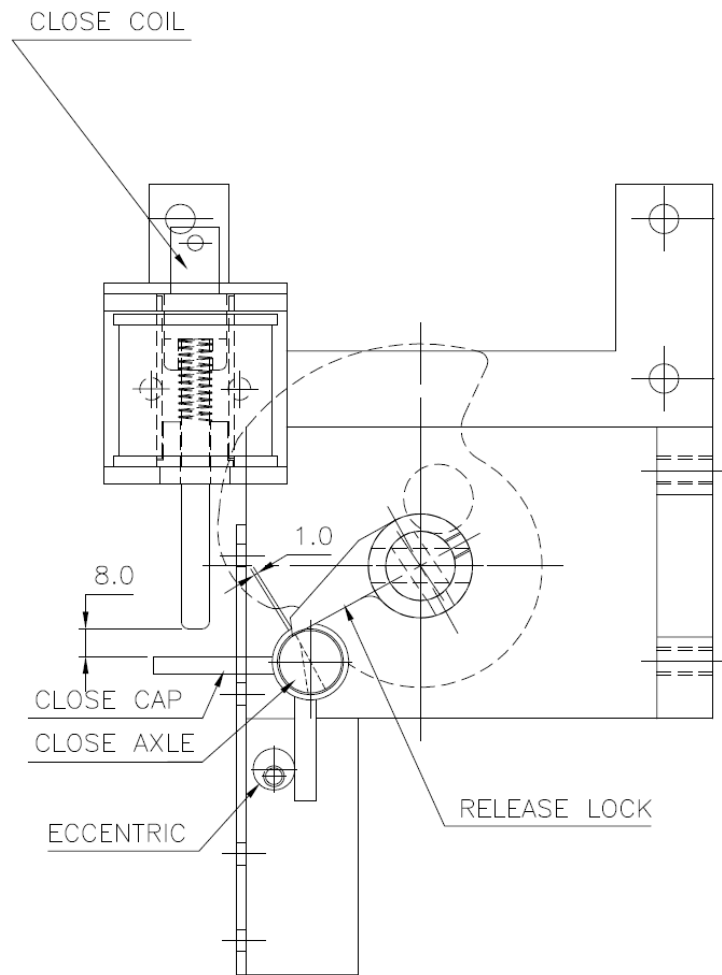
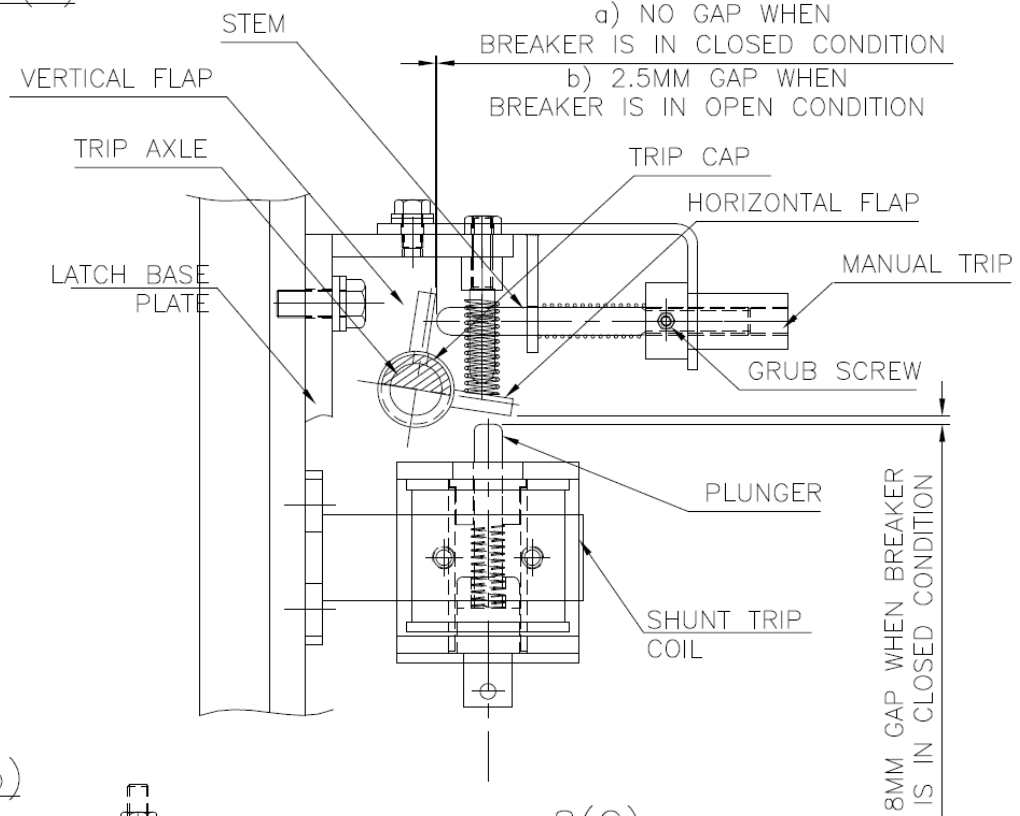
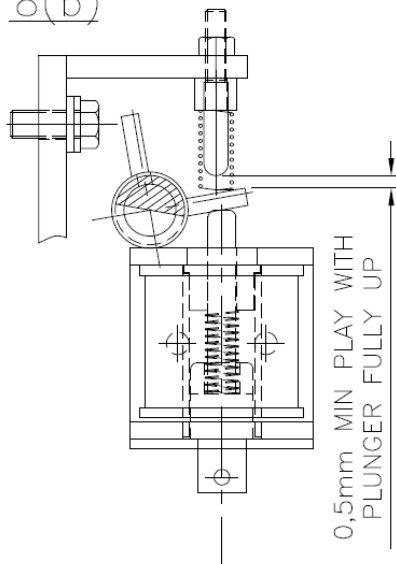

FIG-8

8(a)



8(b)



8(c)

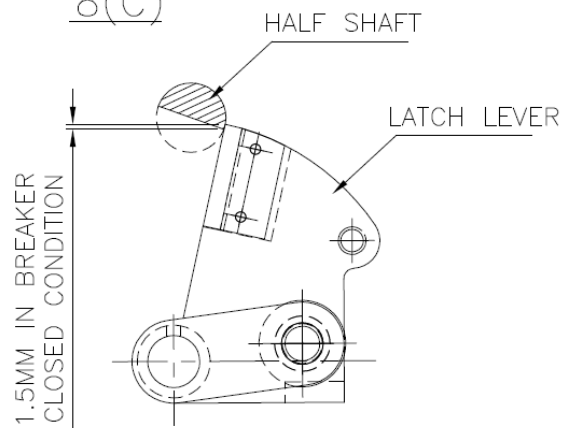

FIG-9

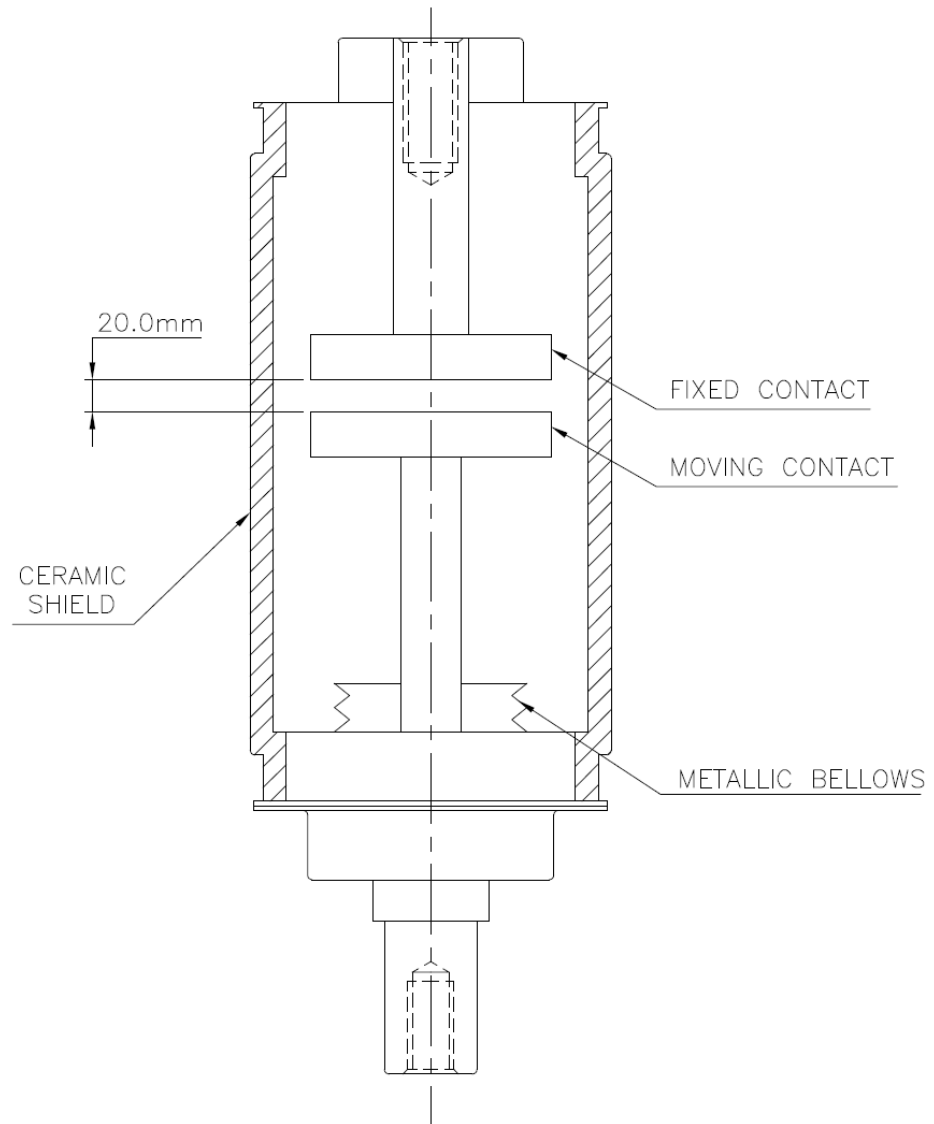

FIG-10

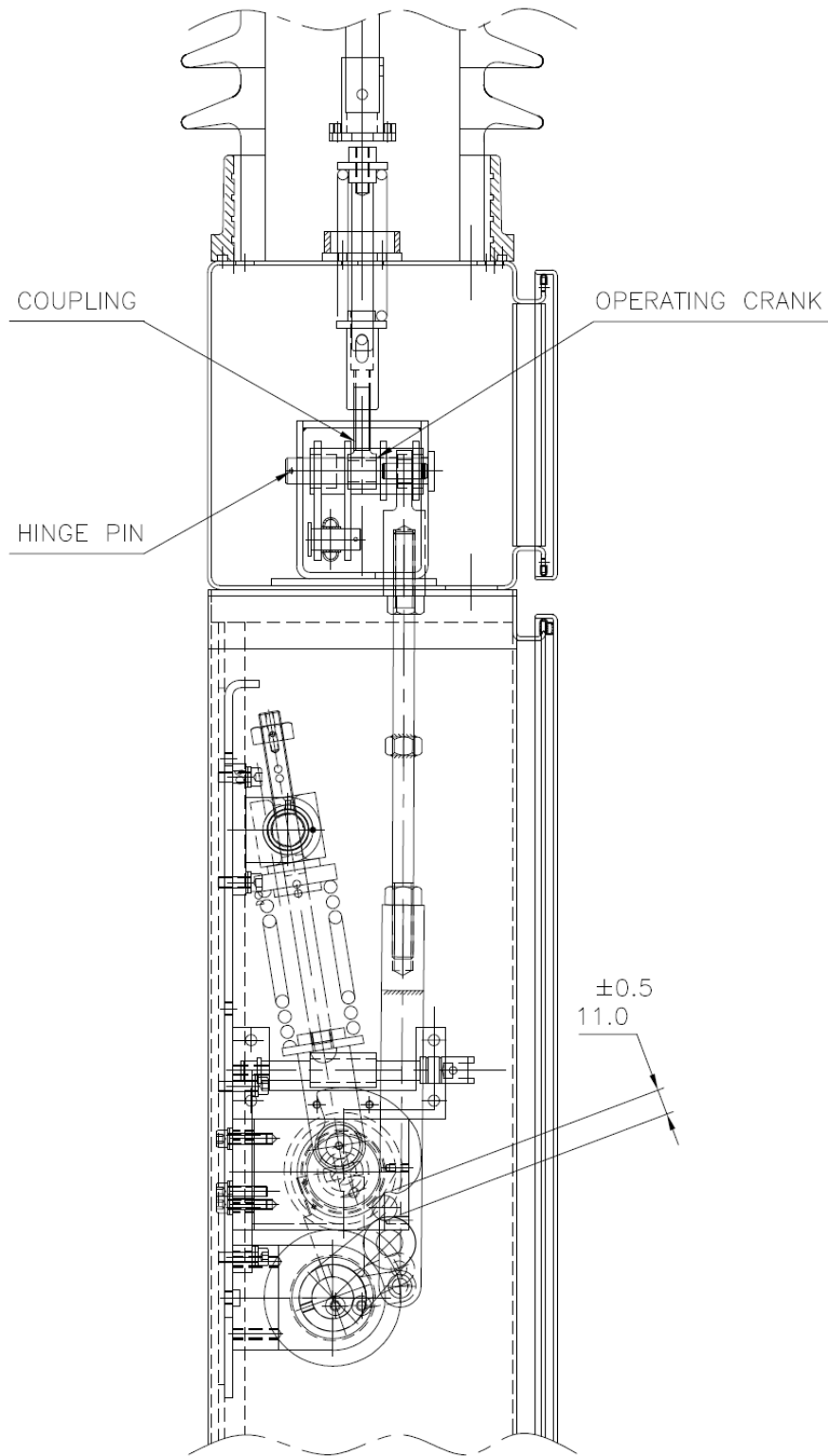
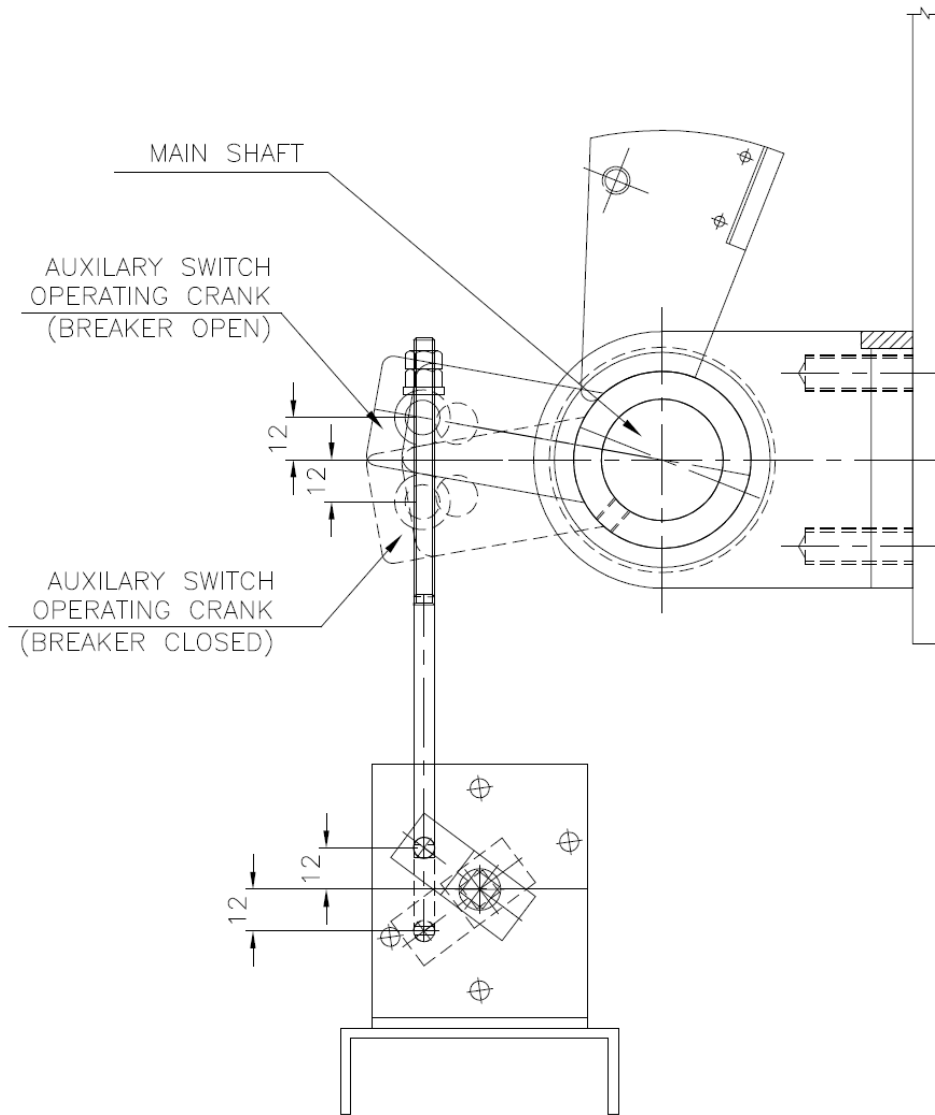

FIG 11



On Load Gears

AUXILIRAY SWITCH SETTING

450 758

R0

FIG 12

THE SETTING OF THE VI IS BASED
ON THE FOLLOWING PRINCIPLES

01. The total stroke of the breaker is 25mm
(Bottle opening + Snatch gap + over travel in closing)

20 to 21	3 to 4	1 to 2
$20 + 3 + 2$	$21 + 3 + 1$	$20 + 4 + 1$
02. The bellcrank travels 12.5mm equally on either side of the horizontal.
03. When bottle is just closed, it has travelled 25mm (13 + 9). This 9mm above horizontal and is called Reset position.

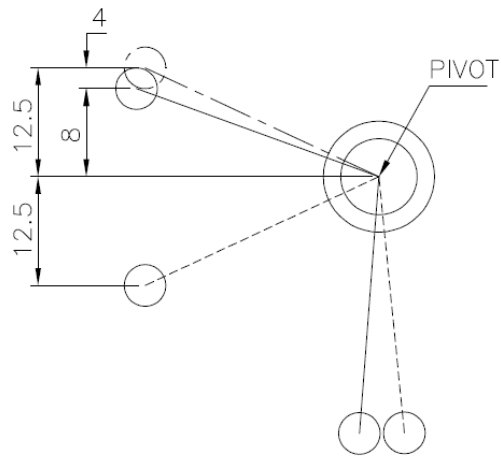

On Load Gears

VI OPENING SETTING

450 759

R0