

ON LOAD GEARS



OPERATIONAL AND MAINTENANCE MANUAL

TAPCHANGER TYPE ABS/SS

We thank you for having purchased OLTC from us. We are sure you will be very happy with the performance, and service of the OLTC you have bought. The OLTC is designed very robustly and very long and satisfactory service may be expected of it.

In the following pages, we describe some simple operational procedures, and routine maintenance requirements and Disposal of product. We hope this Manual would be of use to your day to day operations

CONTENTS

Sl.No.	Description	Page No.
I.	Introduction	1
II.	Type Designation	1
III.	Despatch from works	1
IV.	Instructions for Mounting Tapchanger on Transformer	2
V.	Recommendations for Processing of Tapchanger	3
VI.	Operational checks prior to commissioning	5
VII.	Routine Maintenance	6
VIII.	Major Maintenance & Over – Haul.	6
IX.	Trouble Shooting of Electrical Scheme	7
X.	Disposal of product	9
XI.	Drawings	
	a. Mechanism Linear	10
	b. Mechanism with Pre-Selector.	11
	c. Contact Assy. (Bi-Directional).	12
	d. Contact Assy. (Uni-Directional)	13
	e. Lubrication Instruction	14
XII.	Enclosure	
	a. G.A. of Tapchanger	
	b. Schematic Diagram of OLTC.	
	c. Connection Diagram	
	d. Wiring Diagram	
	e. Terminal Board	
	f. Any special Drawings.	

OPERATION & MAINTENANCE MANUAL

FOR

ON LOAD TAPCHANGERS

TYPE ABS & SS

1. INTRODUCTION :

The ABS & SS range of ON LOAD TAPCHANGER is housed in a sheet steel tank, suitable for mounting on the Flange of the Transformer Tank. An Insulated Terminal Board, with connector stems embedded in Epoxy, forms the separator between the oil systems of the Transformer and Tapchanger. The Drive Mechanism Chamber is an integral part of the tank for low voltage Tapchangers (upto 132KV), but is dismantlable for high voltage jobs. The Tapchanger is protected by a single float Oil Surge Relay for above 11KV class (Optional for 11KV).

2. TYPE DESIGNATION :

The system of type designation of the ABS & range of Tapchanger is as follows:

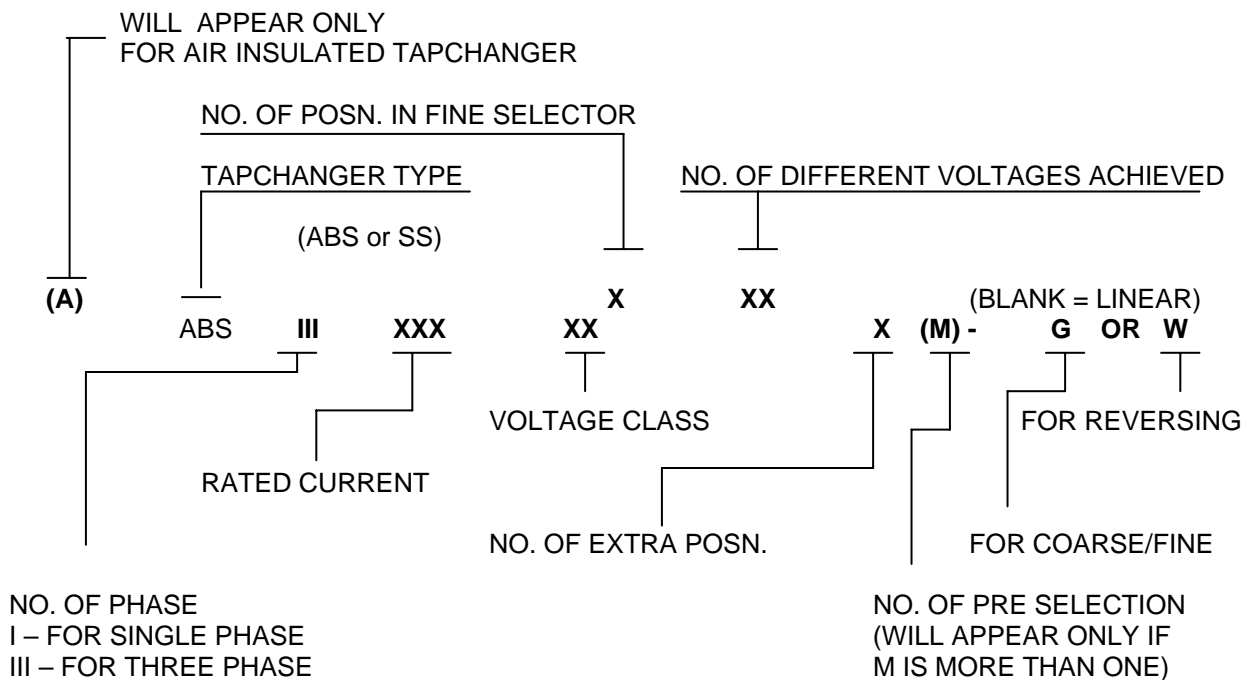

3. DESPATCH FROM WORKS :

The Tapchanger is despatched by us to the Transformer Manufacturer with the following components :

1. Terminal Board – Not for S.S (Terminal Board Integral).
2. For both types ABS & SS, the Drive Mechanism is mounted integrally on the Tapchanger Tank.

3. The Connectors between the Tapchanger and the Terminal Board are sent with one end attached to the respective Tapchanger Contacts and the other end free for connection to the Terminal Board. Tapchanger Voltage Class 33 and above have a small flexible link to take care of thermal expansion is included along with the fastener. For SS, there are no loose Connectors.
4. Oil Surge Operated Relay (Not for SS, except where specifically ordered).
5. Manual operating handle.
6. Key for Drive Mechanism Door Lock.
7. Terminal Board Clamps (for ABS above 11KV)

In general, when the Transformer manufacturer despatches the complete Transformer, he will send the Tapchanger mounted on it. However, in some cases, where Transport is a limiting consideration, he may send some items loose, except that always the Terminal Board will be pre-mounted on the Transformer.

4. INSTRUCTIONS FOR MOUNTING TAPCHANGER ON TRANSFORMER :

The following notes will be of particular interest to the Transformer manufacturer, though they will also help the transformer user in cases where the Tapchanger is sent separate from the Transformer Unit.

1. Clean the Terminal Board with dry cloth, without leaving any fibers. Mount on the Transformer Port opening with Gasket as shown in the General Arrangement Drawing. Note that the Board is marked "Inside Transformer" and "Inside Tapchanger" to indicate where it was mounted.

CAUTION :

1. If the edge of the port opening is not reasonably flat, there is a possibility of cracking the Terminal Board. Therefore, pack with thinner pieces of Gasket where the gap is too high. Such extra packings must be glued to the main gasket, to prevent them coming adrift in service.
 2. Tighten the Board uniformly, starting with the four corners and proceeding diagonally.
 3. Tighten with "feel" so as not to damage the Board.
2. Connect all leads on the Transformer side noting the "Connection Diagram" applicable to your job.

3. Remove the Transport cover on the Tapchanger Port and top hand-hole cover. Clean out any dust that may have got in.

DO NOT USE COMPRESSED AIR UNLESS YOU HAVE AN EFFICIENT MOISTURE TRAP.

Do not leave behind any fibrous extraneous matter.

4. Fit the Tapchanger on the Transformer Flange using a Gasket as shown in the General Arrangement Drawing. Tighten fasteners uniformly and diagonally.

CAUTION: Ensure that the Tapchanger does not strike the Terminal Board due to careless centering of crane or swinging, as the Board may crack.

5. Connect the Tapchanger leads to the Terminal Board. Number marked on the stud is as same as the corresponding Contact Numbers painted on the Rear side of the Phase Board.
6. Operate the Tapchanger by Manual Handle once over the whole Tapping Range, observing at each position that the Tap Number and Ratio are correct, and that Connectors, as can be seen physically, are according to the Connection Diagram.
7. Replace Top Hand-hole Cover and Gasket.
8. Fill Tapchanger, compartment fully with dry, clean, gas free oil. If you do not connect the Conservator for testing the Transformer, ensure that the Oil Level is up to the Relay Connector Pipe Flange.
9. For final Service, it is necessary to connect the Tapchanger to the Conservator through the Oil Surge Relay (Oil Relay may be omitted for 11kV). Release trapped air, using Air Release Plug of Top Cover and OSR Valve and ensure the OSR is in Service position.

5. RECOMMENDATIONS FOR PROCESSING OF TAPCHANGER :

5.1. INTRODUCTION :

Epoxy Resin bonded Glass Filament wound Tubes and Cast Epoxy, which are used as main insulation are almost totally non-hygroscopic. Insulation of this kind is not specifically damaged by exposure to moisture due to whatever reason, for example bad storage. No particular processing is required to regain the full insulation level. When the Tapchanger has been stored for a time, it is enough to wipe all the insulating surfaces with a dry fleece free cloth to remove surface moisture.

In the case of high voltage Tapchangers, and in Tapchangers where paper covered insulation is used, some kind of drying may be desirable. This is discussed below.

5.2. PROCESSING OF TERMINAL BOARD

The Terminal Board is fitted on a port opening on the Transformer Tank. While the Terminal Board is tested for leakage at 1 kg/sq.mm at our factory, it may be risky to subject it to full vacuum when it is mounted on the Transformer port flange. This is because in case of even a slight distortion of the port flange, a Terminal Board may crack due to stresses induced by such distortions.

Therefore, we recommend that whatever processing is used, the Tapchanger Terminal Board is not subjected to a vacuum exceeding 20" of Mercury.

In case of processing the entire Transformer along with the Terminal Board, and Transformer Tank in autoclave, no particular precaution is required, because the Tapchanger is not subjected to any differential pressure. A drying temperature of 100°C may not be exceeded.

If the Transformer is processed in its own tank, it becomes necessary to equalize pressure on both sides of the Terminal Board. This may be done with a temporary cover, or with the Tapchanger tank itself fitted in position. In the later case, please ensure that the atmosphere surrounding the Tapchanger Tank does not exceed 60° C temperature. The equalizer pipe between the Tapchanger Tank and the Transformer Tank must have sufficient section to ensure proper equalization of pressure at all times.

In case where the active parts alone are autoclaved and then inserted in the Transformer Tank, the Terminal Board is not subjected to the usual Transformer processing. In case, it is desired, it can be dried by oil circulation, till the desired least megger value is obtained. Oil temperature should be maintained below 85°C.

5.3. OIL FILLING:

In case where the Transformer Tank and the Tapchanger Tank are fitted together when the Transformer is processed, some care is to be taken with oil filling.

It is better to fill the Transformer Tank first with oil, ensuring that the vacuum pipe equalizer is still in position. This way the pressure differential on the Terminal Board will be maintained within its withstand capability. Oil temperature should not exceed 85°C.

The Tapchanger Tank may also now be filled with oil, preferably by breaking vacuum on both sides of the Terminal Board simultaneously. If on the other hand, it is desired to maintain vacuum, please make sure that the pipe connection is sufficiently large, so that when oil is pumped at a high rate into the Tapchanger Tank, no high pressure is built up.

5.4 PROCESSING AT SITE:

During site operations, if it is found necessary to pull vacuum in the Transformer Tank, please ensure that the Tapchanger Tank is equalized, so that no high differential pressure is developed across the Terminal Board.

For site oil filling also, please refer to Para 3 above regarding oil filling.

5.5 VACUUM WITHSTAND OF TAPCHANGER TANK :

It is confirmed that the Tapchanger Tank is capable of withstanding full vacuum.

5.6 NOTE ON MECHANISM :

In any case, please note that integral drive mechanism is not designed for being processed in the usual manner along with Transformers. This is partly due to the use of insulated wires in the control circuitry and partly due to the use of oils and greases, which do not withstand Transformer processing temperature.

6. OPERATIONAL CHECKS PRIOR TO COMMISSIONING:

Before making any Electrical Connections, operate the Tapchanger manually by means of the Crank Handle once over the entire range of positions, observing particularly the following:

1. The load on the Crank Handle is sensibly uniform (about 2 to 4 kg-m).
2. Transit time by audio and visual perceptions should be fast (about 110 milli sec. Max.)
3. Mechanical End Stops are operational.

Now connect the Main Three Phase 415V supply, taking care of Phase Sequence, indicated by appropriate markings on the Terminal Blocks. Switch on and operate Electrically. At end positions, try to operate in the direction of Over-Drive. Be ready to Switch Off Power, if Motor starts running due to failure of Electrical Limit Operation. (This may happen if the phase sequence of supply is wrong).

The Tapchanger is now ready for service.

7. ROUTINE MAINTENANCE:

Period: Once a year or 6000 operations, which ever is earlier.

1. Apply grease as per our instructions on all Gear Teeth, Geneva Locking Faces and other Mechanical Contact and Bearing surfaces.
2. Wipe the Tap Position Indicator dial switch fixed studs clear and smear a little "Electrolube" oil.
3. Test a sample of oil from the Tapchanger Tank. If not to normal standards (IS 1866), you should filter.
4. Before filtering, wipe all Carbon deposits with clean cloth.
5. While filtering take oil out of the bottom of the tank, and let in filtered oil at top.
6. Observe the general condition of the Main Spring, particularly checking elongation, if any, of holes in the end fittings through which the Spring passes.
7. Keep the Drive Mechanism Cabinet reasonably clean and dry at all times.
8. Check the tension of the Drive Motor Belt & if necessary remove one link to reduce slack.

8. MAJOR MAINTENANCE & OVER-HAUL:

IT IS STRONGLY RECOMMENDED THAT THE ASSISTANCE OF OLG IS TAKEN FOR MAJOR MAINTENANCE AND OVER-HAUL.

1. Schedule for major maintenance and over-haul is as follows:
 - a) For Step Capacity (i.e. step voltage x through current) less than 50KVA every 20,000 operations or five years whichever is earlier.
 - b) For Step Capacity 50-80 KVA every 15,000 operations or four years whichever is earlier.
 - c) For Step Capacity over 80KVA every 12,000 operations or three years whichever is earlier.
 - d) For Step Voltage greater than 850V, irrespective of Step KVA every 12,000 operations or three years whichever is earlier.

2. For major maintenance drain all oil and remove Top Cover.
3. Clean all deposits with non-fibrous, clean cloth.
4. Visually observe all Contacts for Wear. Contacts must be changed if there are signs of heavy Arcing or Pitting. We recommend changing of complete Hinged Roller Contact Assembly or Fixed Contact as necessary.
5. If there are signs of leakage through the Shaft Oil Glands, replace Gland Assembly.
6. If the condition of the Main Springs are seen to be unsatisfactory, replace Spring.
7. In any case we recommend replacement of Main Spring Assembly after every 40,000 operations.

After completing all work, close the Top Hand-hole, and fill with dry, clean, Gas free, tested Transformer Oil.

9. TROUBLE SHOOTING OF ELECTRICAL SCHEME:

PROBLEM NO.1: After fixing the OLTC with the transformer, conduct the Raise/Lower operation through appropriate push button, if the transformer ratio comes in the opposite direction but the OLTC running in right direction.

- i) Verify the Winding and Connection Diagram correspond.

PROBLEM NO.2: Motor not running (is dead)

- i) Check three Phases & Neutral are available at the terminal blocks.
- ii) Check supply ON/OFF Switch (TCSIS) & Local/Remote Switch (CSS-1) are selected properly.
- iii) Check the fuses provided for three phases (FS1, FS2 & FS3) and for 110V supply (FS4 & FS5) are intact.
- iv) Check whether O/L relay (a1) has been tripped due to over current or short circuit. If it is so, reset it manually or put it in auto-reset mode and wait for sometime. Operate few times in presence. Observe O/L relay (a1) tripping, if found analyse the reason whether taking over current or stuck.
- v) Ensure that the manual operating handle is not inserted into operating position before going for electrical operation.
- vi) If RTCC is not used, ensure that the links have been provided as per "ATTENTION LABLE" stuck inside the door.

PROBLEM NO.3: After connecting 3 phase supply to OLTC, while pressing Raise/lower push button, if the main spring charges and discharges automatically.

- i) Check the Phase Sequence of supply and interchange any two phases.

PROBLEM NO.4: Motor not running (but humming noise heard) (Applicable to 3 phase Motor).

- i) Check 3 phases are available at Terminal Block.
- ii) Check all the three fuses provided in the coming line (FS1, FS2 & FS3) are intact.
- iii) Check 3 phases at the overload relay output.

PROBLEM NO.5: Tap position indicator not showing correct number & showing Tap No.73 or more than the Taps available.

- i) Short the terminals No.9, N290. Check the display for “1”, if not showing replace the Tap Position Indicator.
- ii) Check continuity and the values of TPI resistances.
- iii) Check TPI Moving Contact positively making against fixed studs.

PROBLEM NO.6: Tap Changer Stuck.

- i) Check Mechanism freeness.
- ii) Drain oil and check Moving and Fixed Contact welded.
- iii) Check condition of Transition Resistances.
- iv) Check all the Fixed and Roller Contact in all the tap points are free from major arcing and may need replacement.
- v) Check if Tank is distorted, or if Main Insulating Tie Bars damaged.

Specify the following while communicating with OLG to take action from OLG end.

Sl. No. of OLTC :

Type of OLTC :
(Available in Name Plate)

No. of Operation :

Your observation based on this checklist. :

PROBLEM NO.7: On pressing the Push button for Raise/Lower operation, OLTC Operates continuously without stop.

- i. Check DSR & DSL switch function.
- ii. Check SC (Stepping contactor) making function.

10. DISPOSAL OF PRODUCT

This product is environmentally compatible.

In as supplied condition, the product does not incorporate any hazardous substances. In operation, the product does not emit any hazardous materials or gases.

The following types of materials have been used to make up the product:

1. Re-cyclable material
2. Non Re-cyclable material

During disposal of the product, care must be taken to dismantle as far as possible in more environmentally accepted way as Recyclable & Non-cyclable scraps i.e. steel, copper, aluminium, rubber, PVC, Thermocol, cast –resin, oil & glass fiber reinforced materials to be segregated properly.

1. Re-cyclable material

Re-cyclable materials like Steel, Copper, and Aluminium can be reused. In disposal, priority must be given to re-use of the materials which can be recycled.

2. Non Re-cyclable material

Non cyclable materials like Cast resin glass fiber reinforced thermoplastics, thermocol, rubber, porcelain & similar materials can be broken in to pieces & can be used as secured land filling materials.

Rubber being biodegradable material must be recycled through authorized contractors.

PVC and Thermocol material should not be burnt as they may release Halogenated hydrocarbons and Carbon monoxide which can affect the ozone layer. Therefore PVC and Thermocol must be recycled through authorized contractors.

OLTC tank may use transformer oil. When spent, transformer oil inside the OLTC tank is also a hazardous waste. Older oil contains polychlorinated biphenyls (PCBs), a harmful toxin that persists in the environment,

Therefore transformer oil is also likely to be classified as special waste and will require a consignment note for its movement. Seek advice on the disposal of transformer oil from specialist waste contractors.

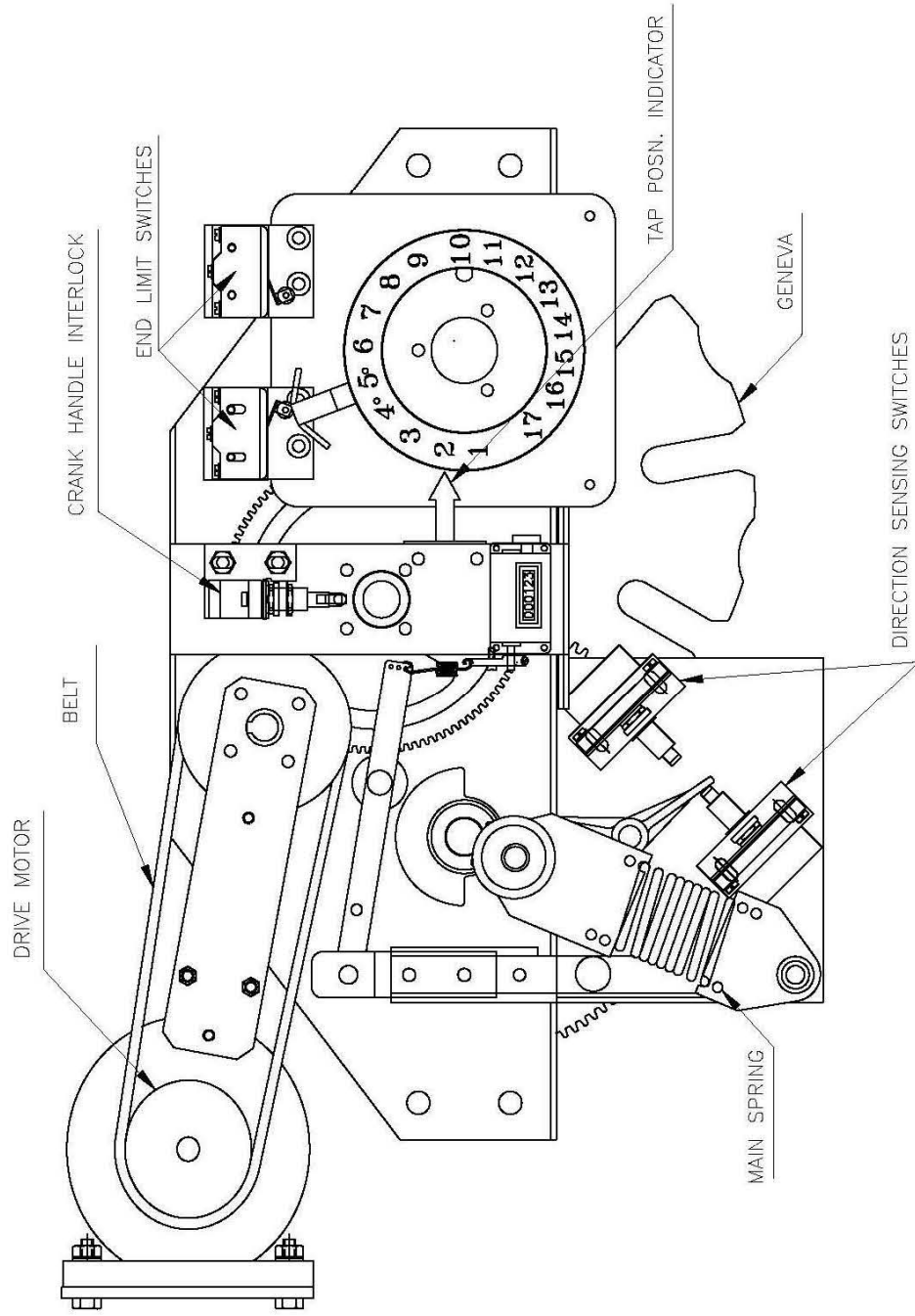
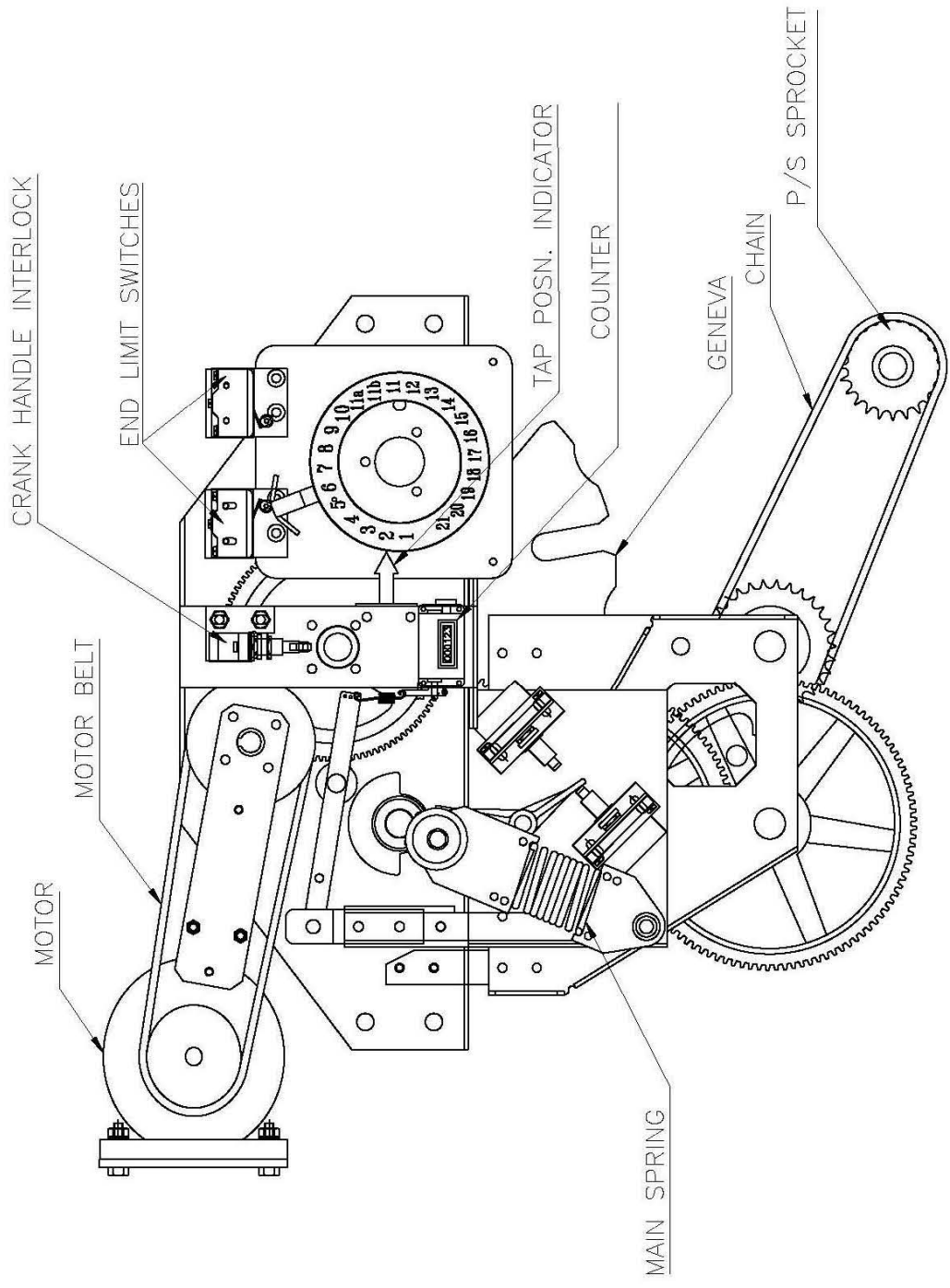

Fig-1



On Load Gears

MECHANISM- WITH PRE SELECTOR

400 069/R1

Fig 1

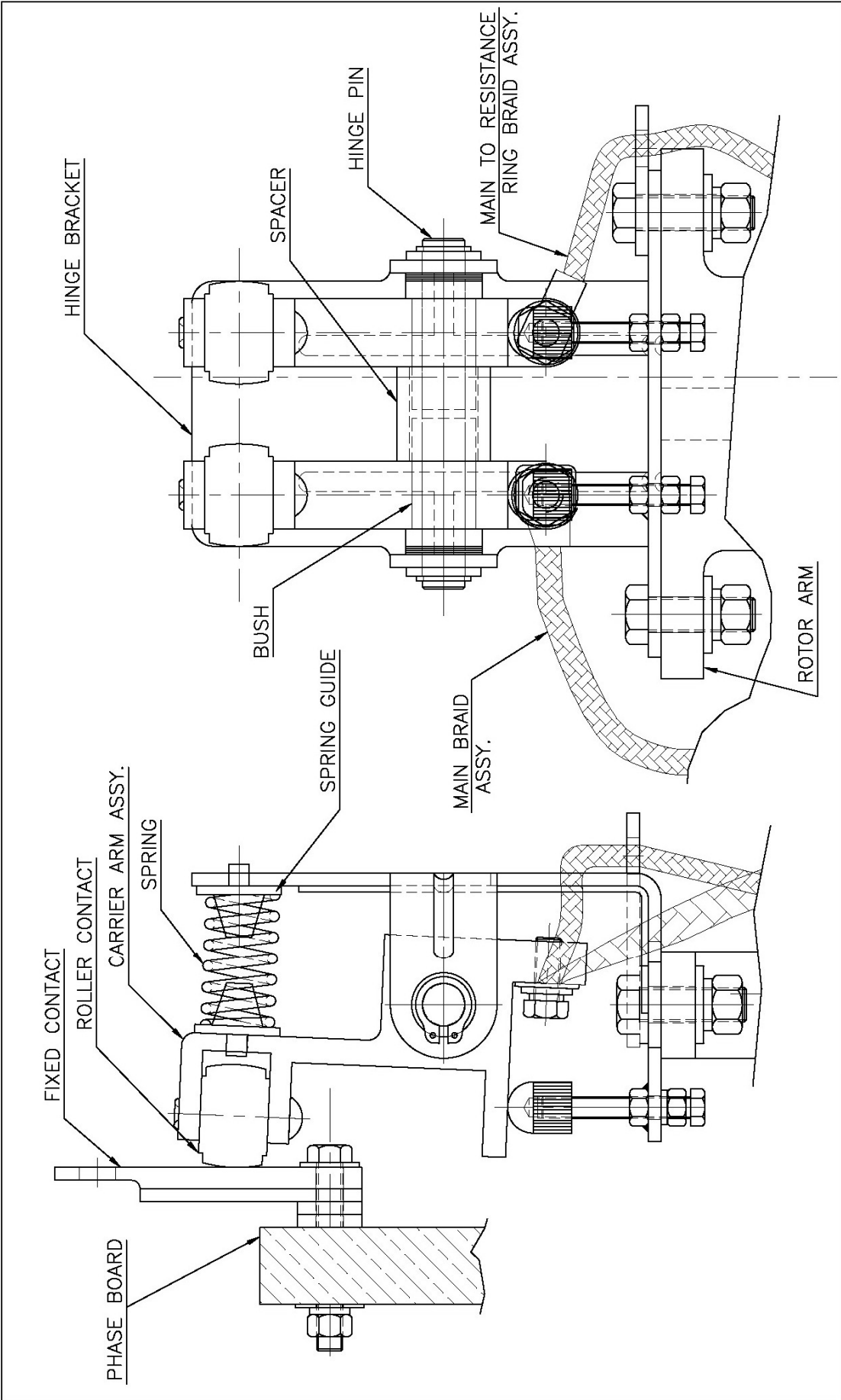

-Fig 3-

On Load Gears

CONTACT ASSY. (UNI-DIRECTION)

400 061

R₁

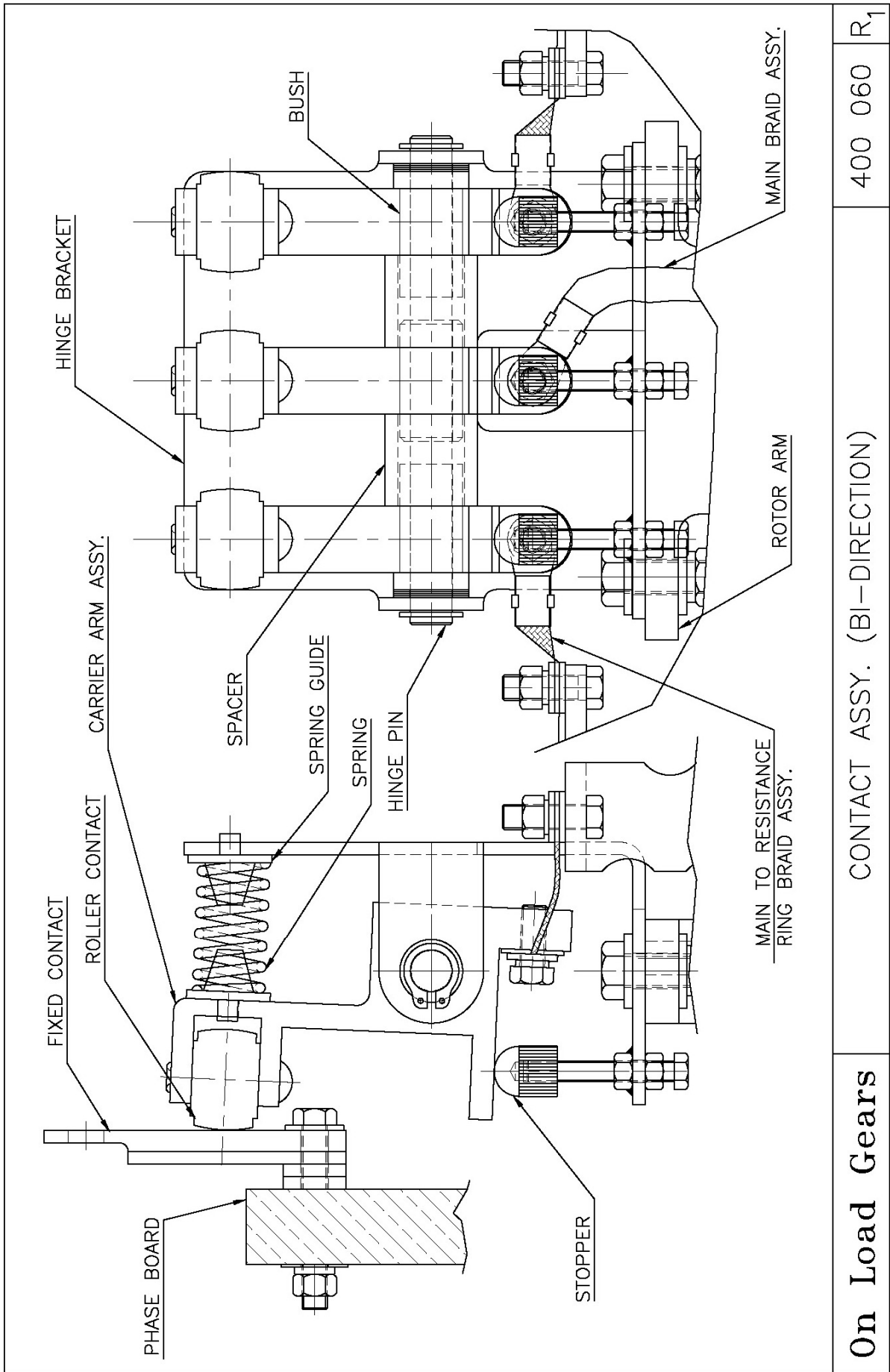

-Fig 4-

On Load Gears

CONTACT ASSY. (BI-DIRECTION)

400 060

R₁

LUBRICATION INSTRUCTIONS

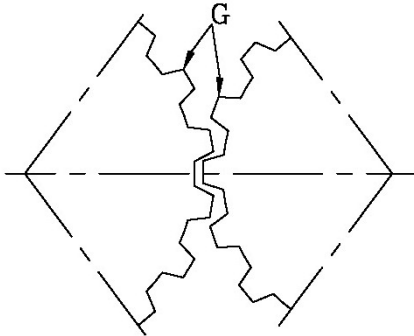

GEAR WHEELS

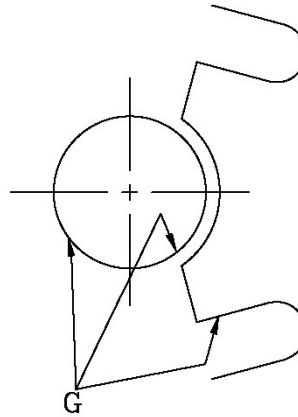

GENEVA & CAM MECHANISM

ONCE IN A YEAR OR 6000 OPERATIONS WHICHEVER IS EARLIER CARRY OUT THE FOLLOWING:

- 1) LUBRICATE ALL GEAR WHEELS, GENEVA CAM MECHANISM & MECH. LIMIT ASSY. AS INDICATED BY 'G' EITHER WITH LITHIUM GREASE OR MOLYBDENUM-DI-SULPHIDE (COMMERCIAL NAME MOSIL BRB-500)**
- 2) FILTER TAPCHANGER OIL.**
- 3) CHECK THE TENSION OF THE DRIVE MOTOR BELT & IF NECESSARY REMOVE ONE LINK.**

 ON LOAD GEARS

432, 433 SIDCO INDL. ESTATE, AMBATTUR, CHENNAI 600 098.